

MODEL LFS50A-5

雑音端子電圧 Conducted Emission

Conditions

Vin: 100VAC / 50Hz
 Iout: 100%
 Limit(QP): — VCCI ClassB
 Limit(AV): — VCCI ClassB

QP Data List

Point	Freq. [Hz]	Limit [dBuV/m]	Margin [dB]
A	210.0k	63.2	13.4
B	209.9k	63.2	12.2
C	2.97M	56.0	17.7

Phase: N

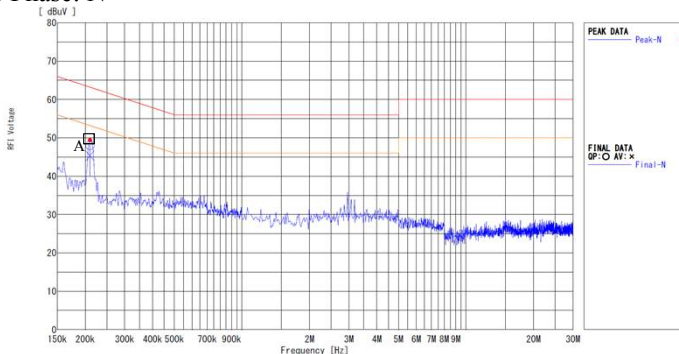

Phase: L

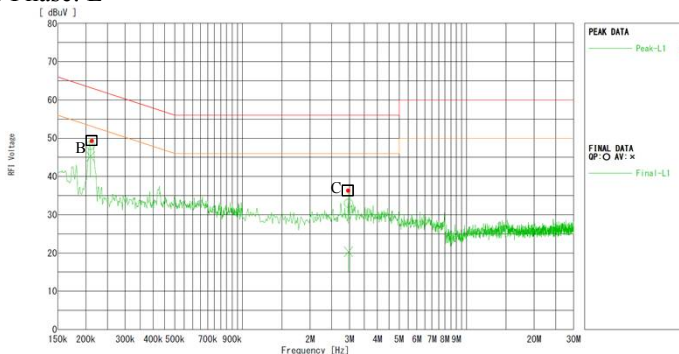

AV Data List

Point	Freq. [Hz]	Limit [dBuV/m]	Margin [dB]
A	210.0k	53.2	7.8
B	209.9k	53.2	7.7
C	2.97M	46.0	25.3

Conditions

Vin: 230VAC / 50Hz
 Iout: 100%
 Limit(QP): — EN55022 ClassB
 Limit(AV): — VCCI ClassB

QP Data List

Point	Freq. [Hz]	Limit [dBuV/m]	Margin [dB]
A	211.3k	63.2	13.4
B	3.62M	56.0	15.2
C	3.82M	56.0	16.2
D	211.6k	63.1	12.9
E	3.63M	56.0	15.1
F	3.83M	56.0	15.7

Phase: N

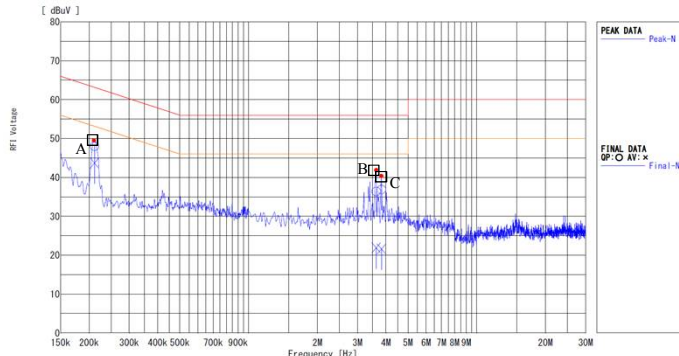

Phase: L

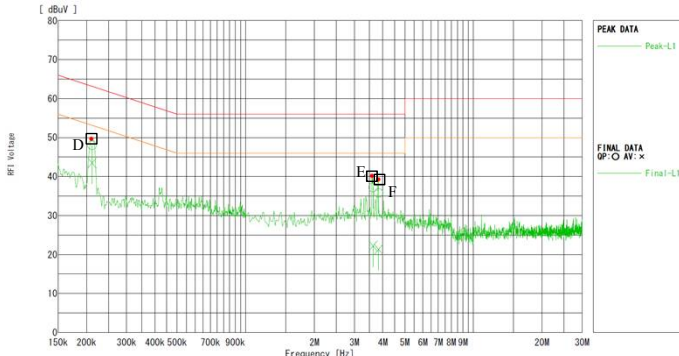

AV Data List

Point	Freq. [Hz]	Limit [dBuV/m]	Margin [dB]
A	211.3k	53.2	9.6
B	3.62M	46.0	23.7
C	3.82M	46.0	24.6
D	211.6k	53.1	9.8
E	3.63M	46.0	23.7
F	3.83M	46.0	24.6

MODEL LFS50A-12

雑音端子電圧 Conducted Emission

Conditions

Vin: 100VAC / 50Hz
 Iout: 100%
 Limit(QP): — VCCI ClassB
 Limit(AV): — VCCI ClassB

QP Data List

Point	Freq. [Hz]	Limit [dBuV/m]	Margin [dB]
A	152.5k	65.9	18.1
B	196.3k	63.8	17.2
C	197.1k	63.7	16.8

Phase: N

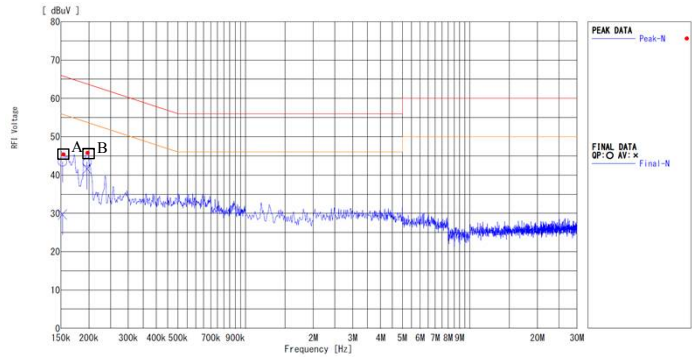

Phase: L

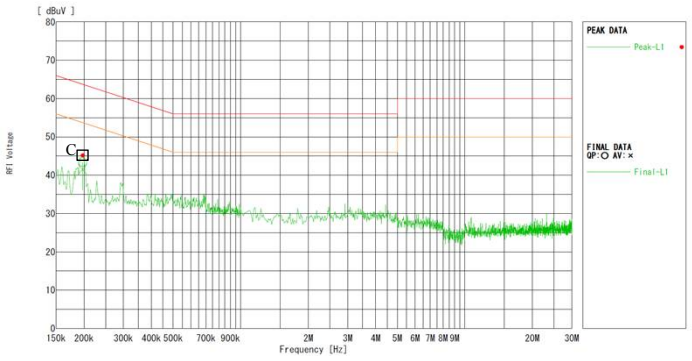

AV Data List

Point	Freq. [Hz]	Limit [dBuV/m]	Margin [dB]
A	152.5k	55.9	26.1
B	196.3k	53.8	12.2
C	197.1k	53.7	12.1

Conditions

Vin: 230VAC / 50Hz
 Iout: 100%
 Limit(QP): — EN55022 ClassB
 Limit(AV): — VCCI ClassB

QP Data List

Point	Freq. [Hz]	Limit [dBuV/m]	Margin [dB]
A	150.4k	66.0	14.7
B	197.9k	63.7	14.3
C	273.5k	61.0	15.4
D	198.2k	63.7	16.2
E	274.2k	61.0	15.7

Phase: N

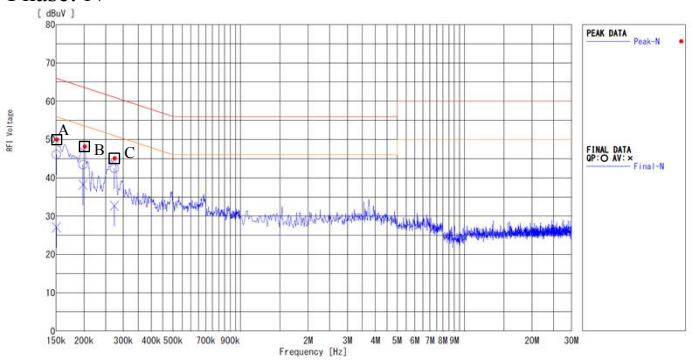

Phase: L

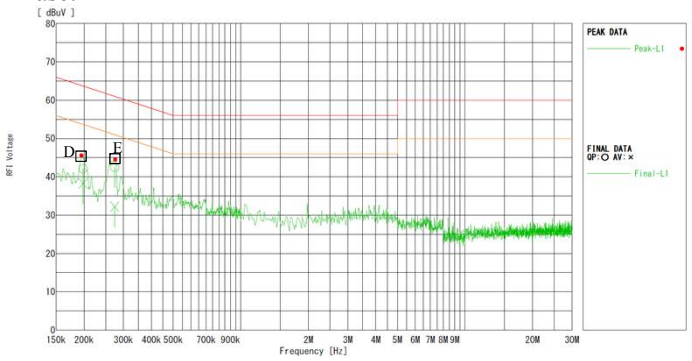

AV Data List

Point	Freq. [Hz]	Limit [dBuV/m]	Margin [dB]
A	150.4k	56.0	28.7
B	197.9k	53.7	15.3
C	273.5k	51.0	17.8
D	198.2k	53.7	15.3
E	274.2k	51.0	18.7

MODEL LFS50A-15

雑音端子電圧 Conducted Emission

Conditions

Vin: 100VAC / 50Hz
 Iout: 100%
 Limit(QP): — VCCI ClassB
 Limit(AV): — VCCI ClassB

QP Data List

Point	Freq. [Hz]	Limit [dBuV/m]	Margin [dB]
A	150.9k	66.0	16.0
B	195.3k	63.8	18.0

Phase: N

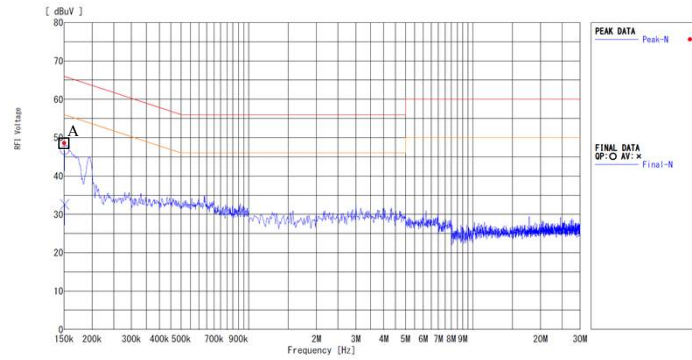

Phase: L

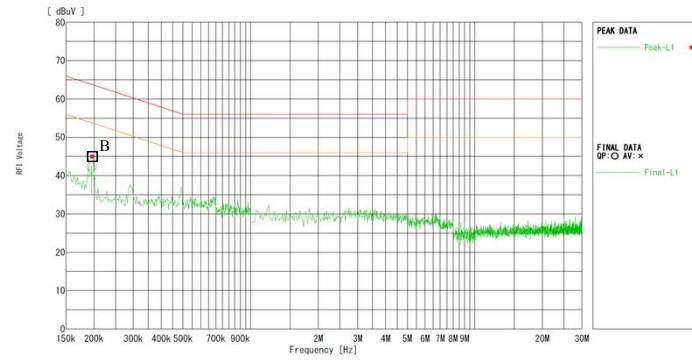

AV Data List

Point	Freq. [Hz]	Limit [dBuV/m]	Margin [dB]
A	150.9k	56.0	23.5
B	195.3k	53.8	13.1

Conditions

Vin: 230VAC / 50Hz
 Iout: 100%
 Limit(QP): — EN55022 ClassB
 Limit(AV): — VCCI ClassB

QP Data List

Point	Freq. [Hz]	Limit [dBuV/m]	Margin [dB]
A	150.7k	66.0	13.1
B	192.3k	63.9	14.1
C	192.2k	63.9	17.2

Phase: N

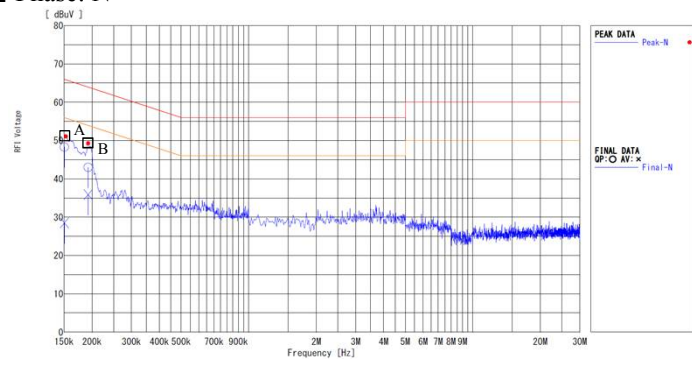

Phase: L

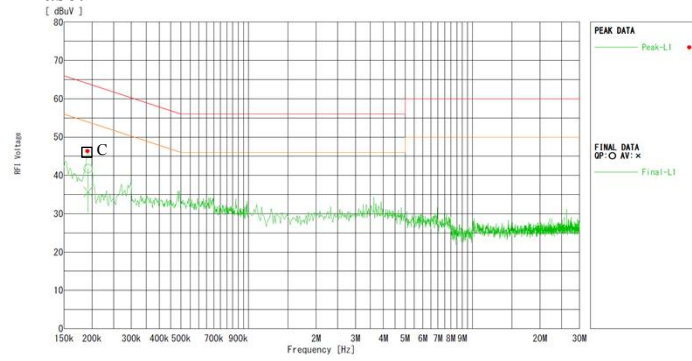

AV Data List

Point	Freq. [Hz]	Limit [dBuV/m]	Margin [dB]
A	150.7k	56.0	27.4
B	192.3k	53.9	18.0
C	192.2k	53.9	18.0

MODEL LFS50A-24

雑音端子電圧 Conducted Emission

Conditions

Vin: 100VAC / 50Hz
 Iout: 100%
 Limit(QP): — VCCI ClassB
 Limit(AV): — VCCI ClassB

QP Data List

Point	Freq. [Hz]	Limit [dBuV/m]	Margin [dB]
A	155.5k	65.7	18.6

Phase: N

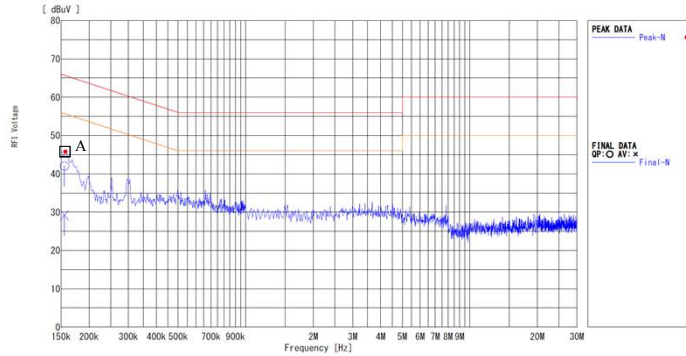

Phase: L

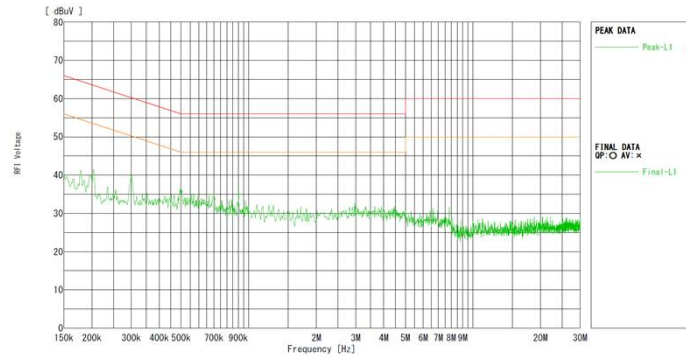

AV Data List

Point	Freq. [Hz]	Limit [dBuV/m]	Margin [dB]
A	155.5k	55.7	26.6

Conditions

Vin: 230VAC / 50Hz
 Iout: 100%
 Limit(QP): — EN55022 ClassB
 Limit(AV): — VCCI ClassB

QP Data List

Point	Freq. [Hz]	Limit [dBuV/m]	Margin [dB]
A	150.5k	66.0	15.7
B	301.0k	60.2	20.2

Phase: N

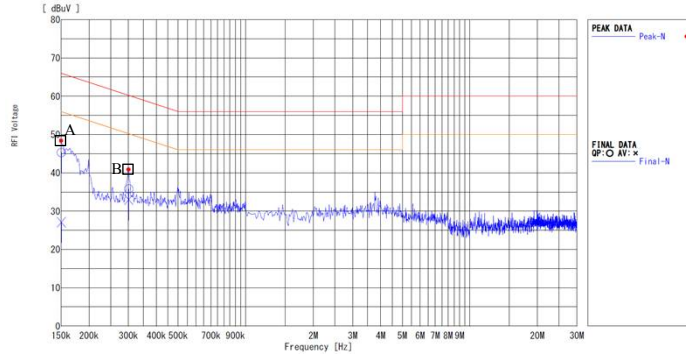

Phase: L

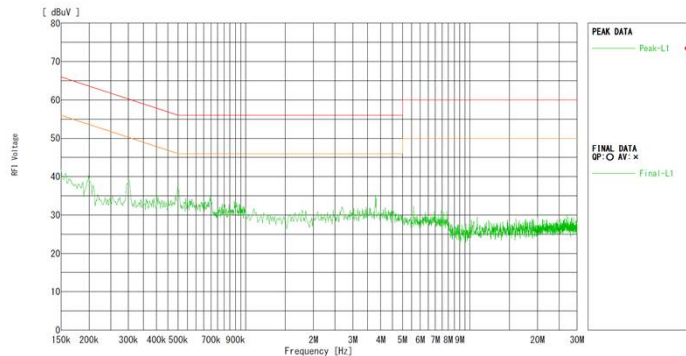

AV Data List

Point	Freq. [Hz]	Limit [dBuV/m]	Margin [dB]
A	150.5k	56.0	29.0
B	301.0k	50.2	17.0

MODEL LFS50A-30

雑音端子電圧 Conducted Emission

Conditions

Vin: 100VAC / 50Hz
 Iout: 100%
 Limit(QP): — VCCI ClassB
 Limit(AV): — VCCI ClassB

QP Data List

Point	Freq. [Hz]	Limit [dBuV/m]	Margin [dB]
A	150.5k	66.0	16.5

Phase: N

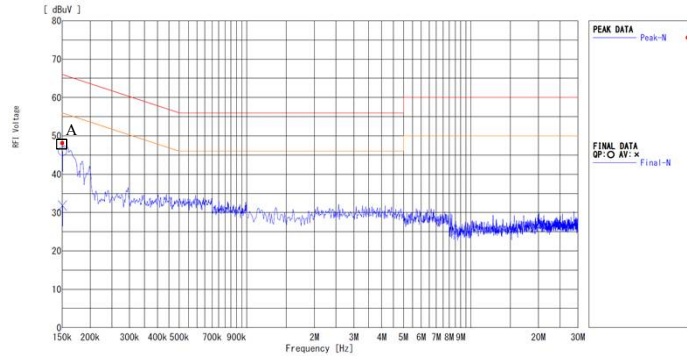

Phase: L

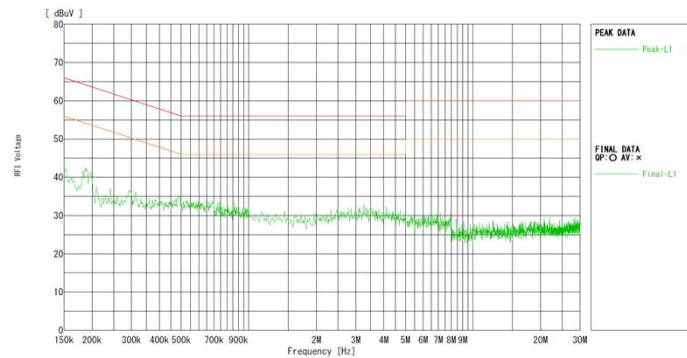

AV Data List

Point	Freq. [Hz]	Limit [dBuV/m]	Margin [dB]
A	150.5k	56.0	24.2

Conditions

Vin: 230VAC / 50Hz
 Iout: 100%
 Limit(QP): — EN55022 ClassB
 Limit(AV): — VCCI ClassB

QP Data List

Point	Freq. [Hz]	Limit [dBuV/m]	Margin [dB]
A	150.0k	66.0	13.7

Phase: N

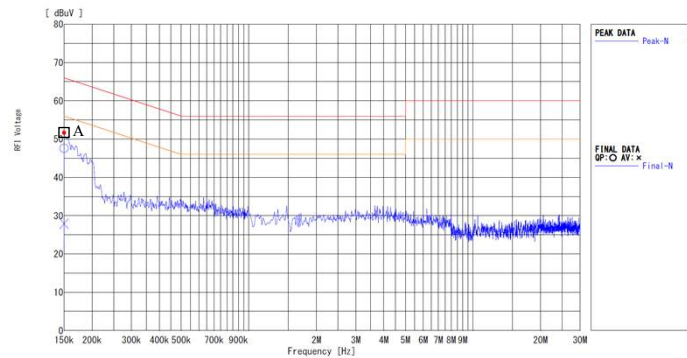

Phase: L

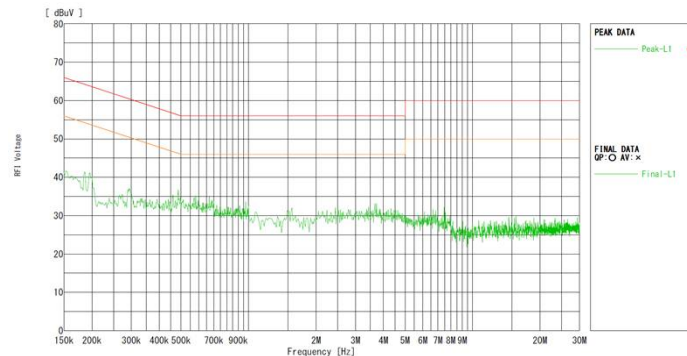

AV Data List

Point	Freq. [Hz]	Limit [dBuV/m]	Margin [dB]
A	150.0k	56.0	28.3

MODEL | LFS50A-48

雑音端子電圧 Conducted Emission

Conditions

Vin: 100VAC / 50Hz
 Iout: 100%
 Limit(QP): — VCCI ClassB
 Limit(AV): — VCCI ClassB

QP Data List

Point	Freq. [Hz]	Limit [dBuV/m]	Margin [dB]

AV Data List

Point	Freq. [Hz]	Limit [dBuV/m]	Margin [dB]

Phase: N

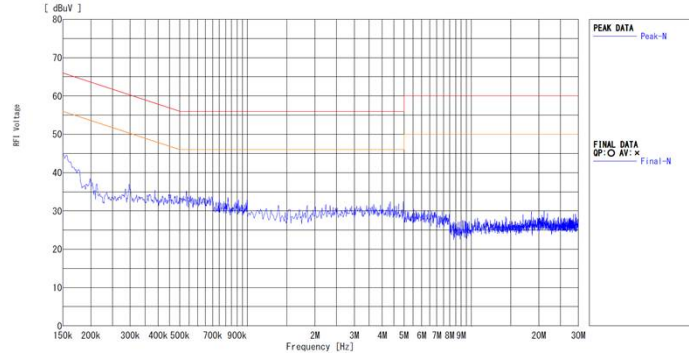

Phase: L

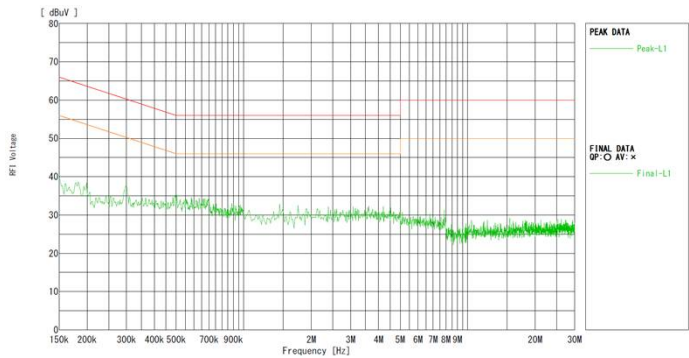

Conditions

Vin: 230VAC / 50Hz
 Iout: 100%
 Limit(QP): — EN55022 ClassB
 Limit(AV): — VCCI ClassB

QP Data List

Point	Freq. [Hz]	Limit [dBuV/m]	Margin [dB]
A	150.9k	65.9	16.9
B	3.80M	56.0	19.5
C	3.79M	56.0	18.5

AV Data List

Point	Freq. [Hz]	Limit [dBuV/m]	Margin [dB]
A	150.9k	55.9	29.1
B	3.80M	46.0	25.3
C	3.79M	46.0	25.3

Phase: N

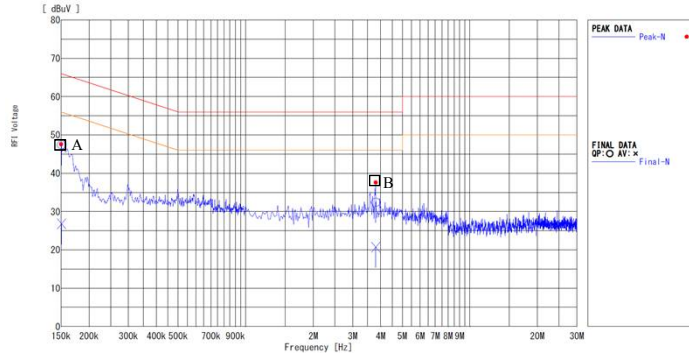

Phase: L

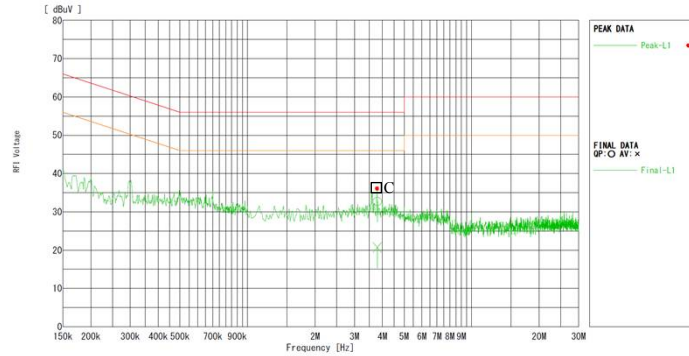

MODEL LFS50A-5

雑音電界強度 Radiated Emission

Conditions

Vin: 100VAC / 50Hz
 Iout: 100%
 Limit(QP): — VCCI ClassB

QP Data List

Point	Freq. [Hz]	Limit [dBuV/m]	Margin [dB]

■ 水平 HORIZONTAL

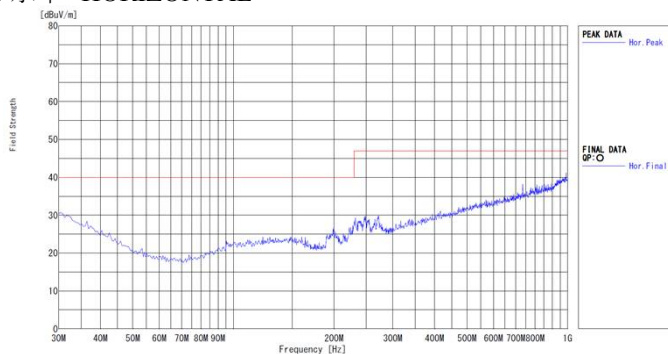

■ 垂直 VERTICAL

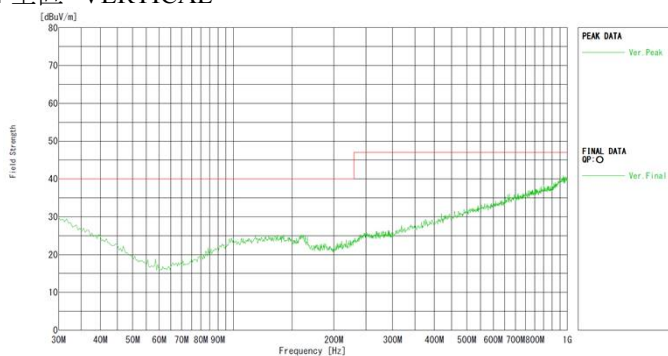

Conditions

Vin: 230VAC / 50Hz
 Iout: 100%
 Limit(QP): — EN55022 ClassB

QP Data List

Point	Freq. [Hz]	Limit [dBuV/m]	Margin [dB]

■ 水平 HORIZONTAL

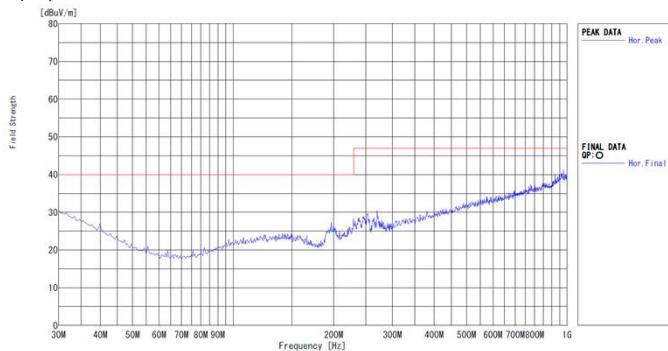

■ 垂直 VERTICAL

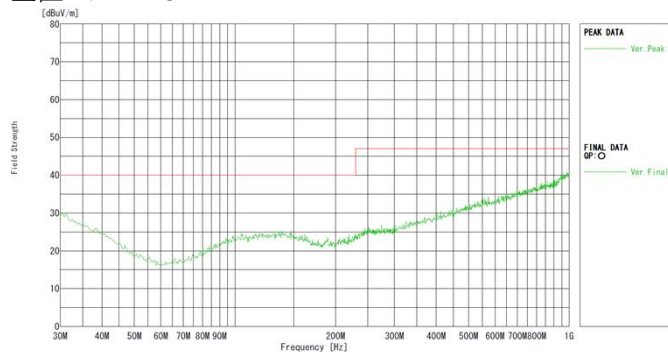

MODEL | LFS50A-12

雑音電界強度 Radiated Emission

Conditions

Vin: 100VAC / 50Hz
 Iout: 100%
 Limit(QP): — VCCI ClassB

QP Data List

Point	Freq. [Hz]	Limit [dBuV/m]	Margin [dB]
A	161.0M	40.0	19.6

■ 水平 HORIZONTAL

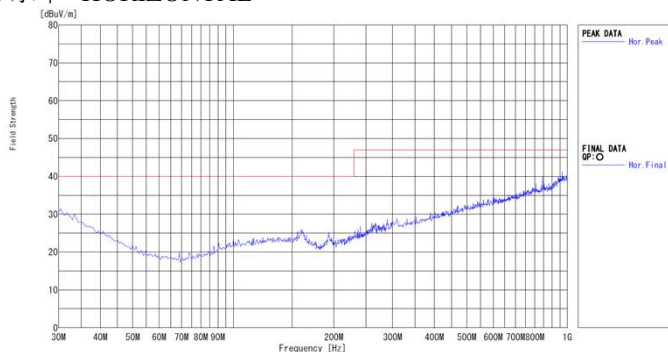

■ 垂直 VERTICAL

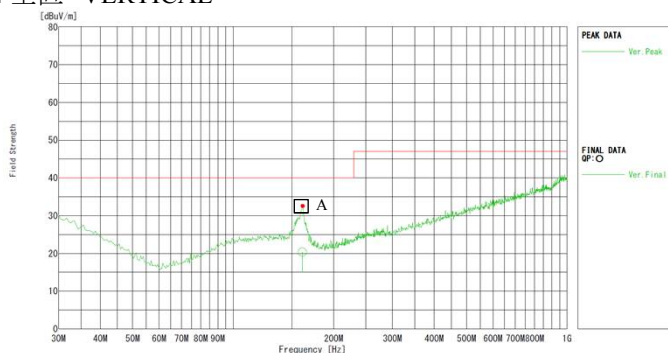

Conditions

Vin: 230VAC / 50Hz
 Iout: 100%
 Limit(QP): — EN55022 ClassB

QP Data List

Point	Freq. [Hz]	Limit [dBuV/m]	Margin [dB]

■ 水平 HORIZONTAL

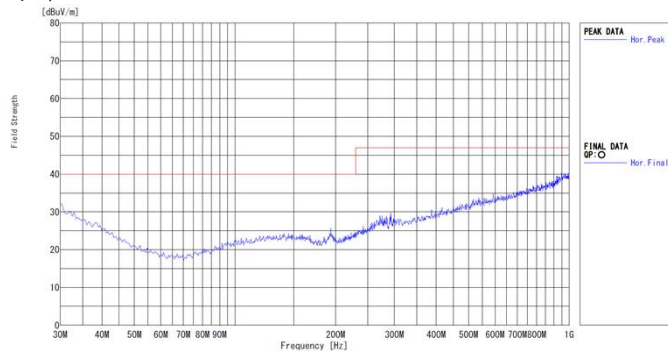

■ 垂直 VERTICAL

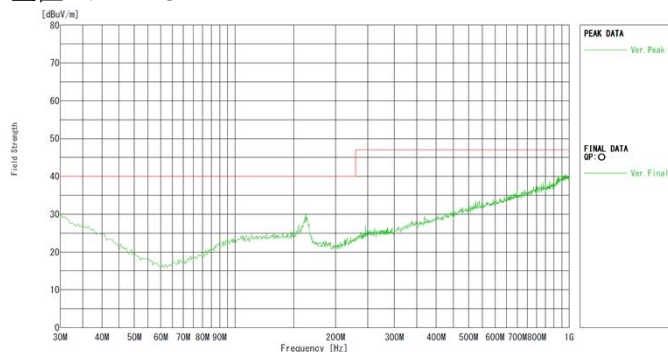

MODEL LFS50A-15

雑音電界強度 Radiated Emission

Conditions

Vin: 100VAC / 50Hz
 Iout: 100%
 Limit(QP): — VCCI ClassB

QP Data List

Point	Freq. [Hz]	Limit [dBuV/m]	Margin [dB]
A	270.3M	47.0	23.5

■ 水平 HORIZONTAL

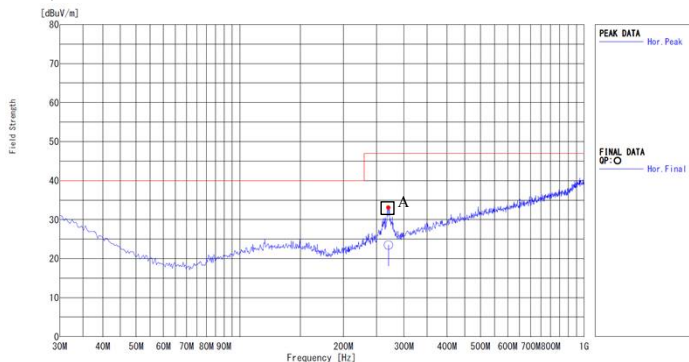

■ 垂直 VERTICAL

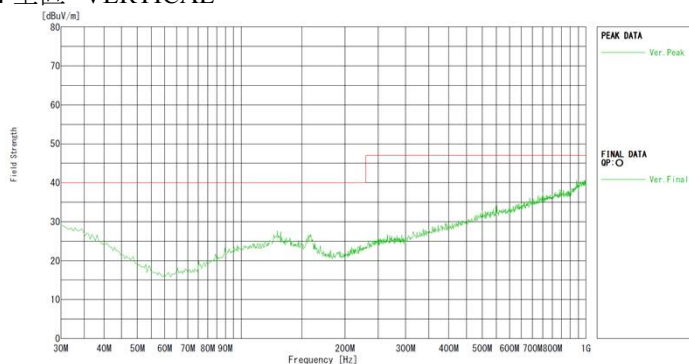

Conditions

Vin: 230VAC / 50Hz
 Iout: 100%
 Limit(QP): — EN55022 ClassB

QP Data List

Point	Freq. [Hz]	Limit [dBuV/m]	Margin [dB]

■ 水平 HORIZONTAL

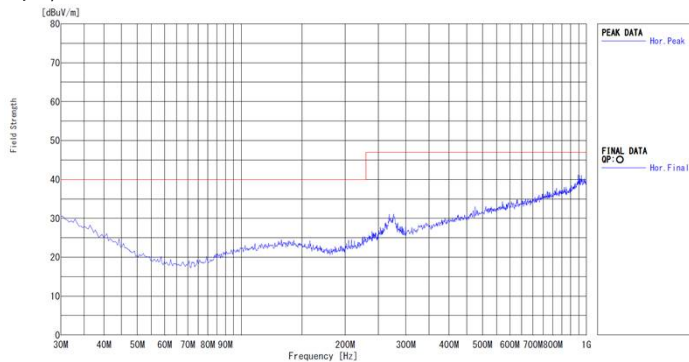

■ 垂直 VERTICAL

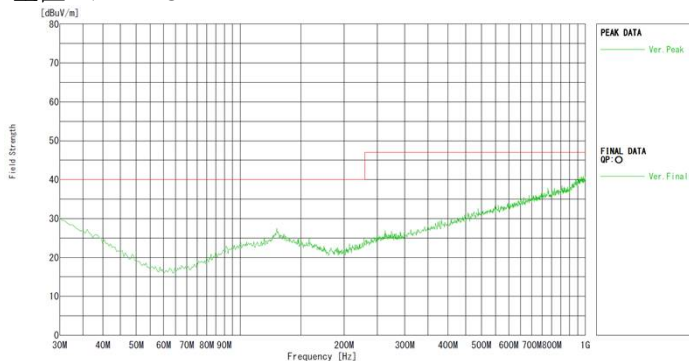

MODEL LFS50A-24

雑音電界強度 Radiated Emission

Conditions

Vin: 100VAC / 50Hz
 Iout: 100%
 Limit(QP): — VCCI ClassB

QP Data List

Point	Freq. [Hz]	Limit [dBuV/m]	Margin [dB]
A	157.7M	40.0	18.3

■ 水平 HORIZONTAL

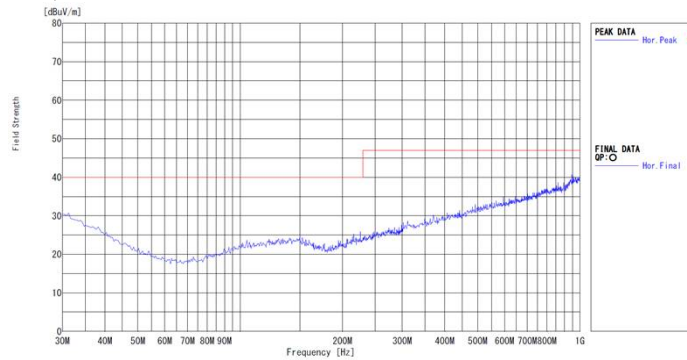

■ 垂直 VERTICAL

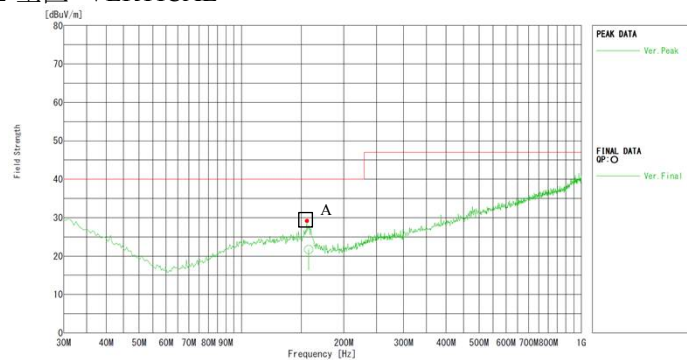

Conditions

Vin: 230VAC / 50Hz
 Iout: 100%
 Limit(QP): — EN55022 ClassB

QP Data List

Point	Freq. [Hz]	Limit [dBuV/m]	Margin [dB]

■ 水平 HORIZONTAL

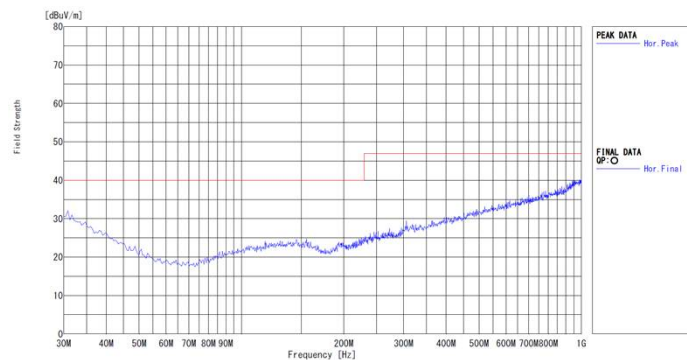

■ 垂直 VERTICAL

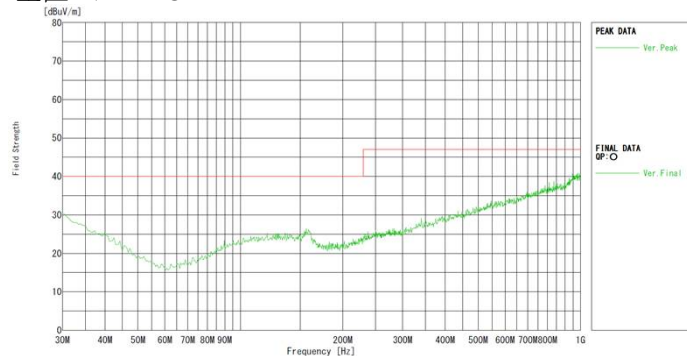

MODEL | **LFS50A-30**

雑音電界強度
Radiated Emission

Conditions

Vin: 100VAC / 50Hz
Iout: 100%
Limit(QP): — VCCI ClassB

QP Data List

Point	Freq. [Hz]	Limit [dBuV/m]	Margin [dB]

■ 水平 HORIZONTAL

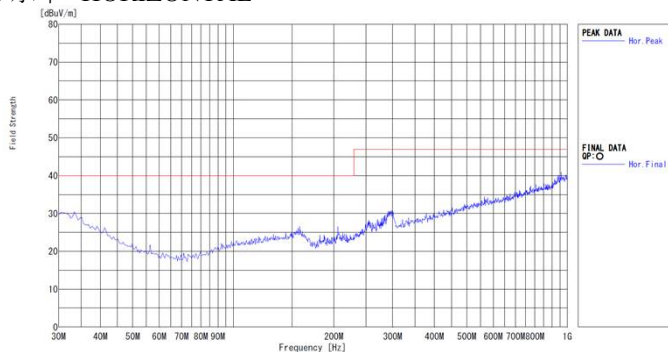

■ 垂直 VERTICAL

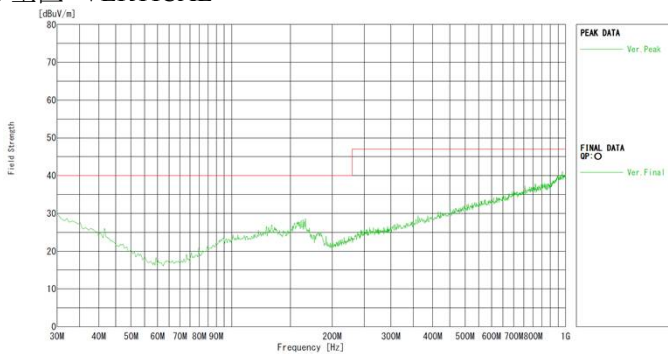

Conditions

Vin: 230VAC / 50Hz
Iout: 100%
Limit(QP): — EN55022 ClassB

QP Data List

Point	Freq. [Hz]	Limit [dBuV/m]	Margin [dB]

■ 水平 HORIZONTAL

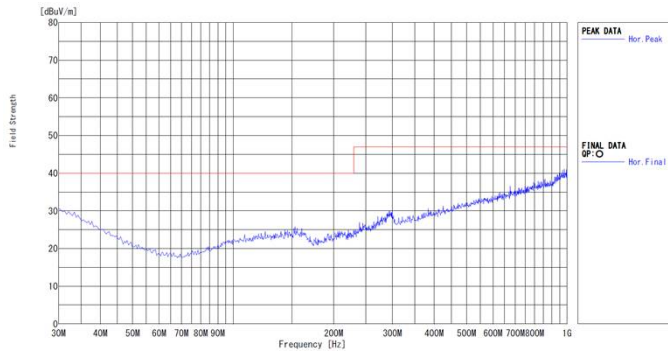

■ 垂直 VERTICAL

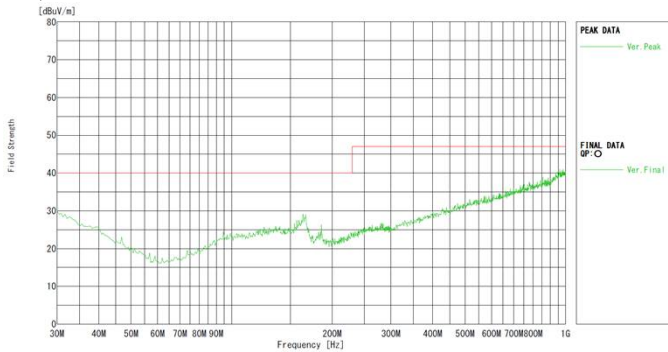

MODEL | **LFS50A-48**

雑音電界強度
Radiated Emission

Conditions

Vin: 100VAC / 50Hz
Iout: 100%
Limit(QP): — VCCI ClassB

QP Data List

Point	Freq. [Hz]	Limit [dBuV/m]	Margin [dB]

■ 水平 HORIZONTAL

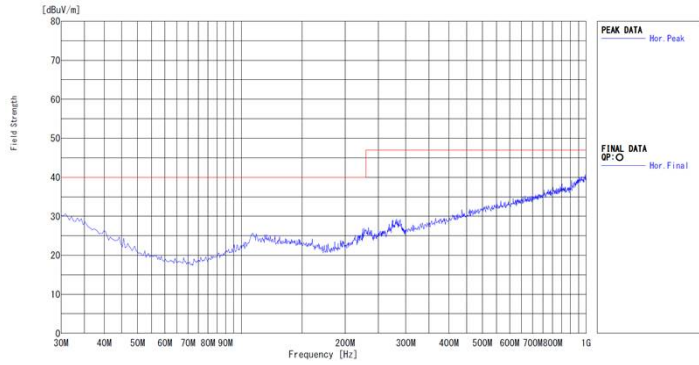

■ 垂直 VERTICAL

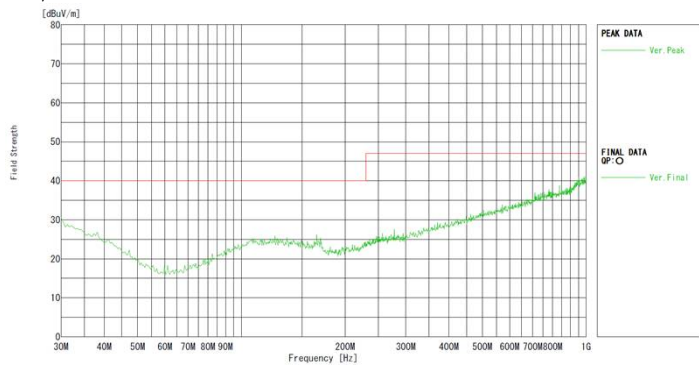

Conditions

Vin: 230VAC / 50Hz
Iout: 100%
Limit(QP): — EN55022 ClassB

QP Data List

Point	Freq. [Hz]	Limit [dBuV/m]	Margin [dB]

■ 水平 HORIZONTAL

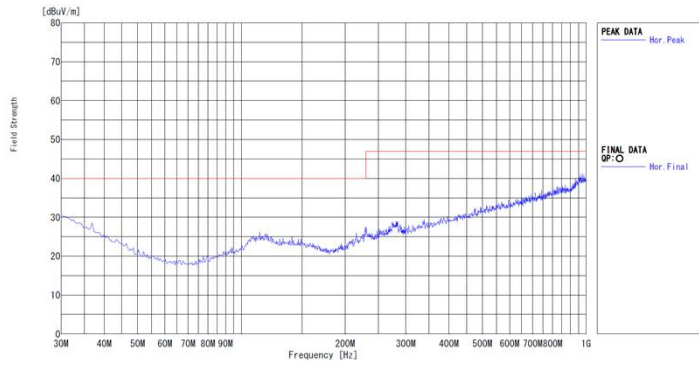

■ 垂直 VERTICAL

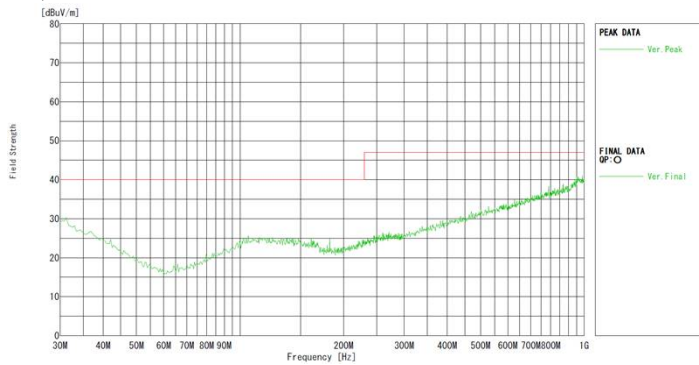

MODEL LFS50A
静電気放電イミュニティ試験
Electrostatic Discharge Immunity Test(EN61000-4-2)

1.使用試験装置 Equipment used

- ・静電気試験器 Electrostatic discharge simulator
- ・放電ガン Discharge gun
- ・静電容量 Capacity : 150pF ・放電抵抗 Discharge Resistance : 330Ω

2.試験条件 Test conditions

- ・カバー付き with Cover
- ・周囲温度 Ambient temperature : 25 °C
- ・入力電圧 Input voltage : 100 , 230 VAC
- ・出力電圧 Output voltage : 定格 Rated
- ・出力電流 Output current : 100 %
- ・試験回数 Number of tests : 10回 10 times
- ・極性 Polarity : + , -
- ・放電間隔 Discharge interval : > 1 s

3.試験方法及び印加箇所 Test method and Device test points

- ・接触放電 Contact discharge : シャーシ, カバー, ネジ取り付け部
- ・気中放電 Air discharge : シャーシ, カバー

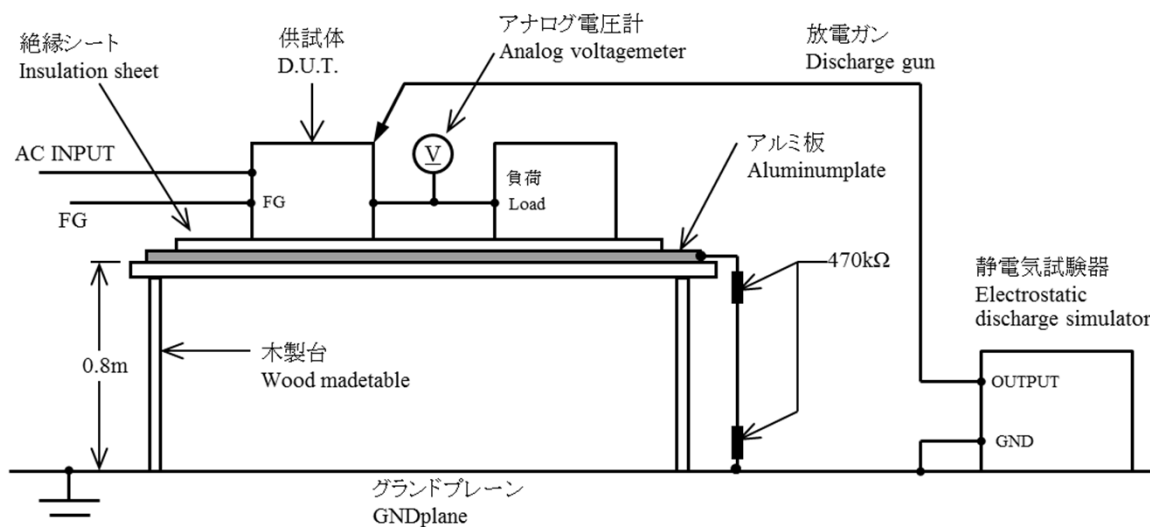

4.判定条件 Acceptable conditions

- ・試験中の出力電圧変動は、初期値(試験前)の±5%を超えないこと。
Output voltage regulation must not exceed ±5% of initial (before test) value during test.
- ・試験後の出力電圧は、初期値(試験前)から仕様範囲内の変動であること。
Output voltage after test shall be stable at the initial (before test) value (within specification range).
- ・試験中、発煙/発火及び出力低下が無いこと。
No discharge of fire or smoke, as well as no output failure during test.

5.試験結果 Test result

・接触放電 Contact discharge

LEVEL	Contact discharge (kV)	Result
1	2	OK
2	4	OK
3	6	OK
4	8	OK

・気中放電 Air discharge

LEVEL	Airt discharge (kV)	Result
1	2	OK
2	4	OK
3	8	OK
4	15	OK

MODEL LFS50A

放射無線周波数電磁界イミュニティ試験

Radiated Radio-Frequency Electromagnetic Field Immunity Test(EN61000-4-3)

1.使用試験装置 Equipment used

- ・放射イミュニティ測定システム Radiation immunity measurement system
- ・アンテナ Antenna
 - バイログアンテナ Bilog antenna
 - スタックド・ダブルログペリアンテナ Stacked Microwave Log.-Per. Antenna

2.試験条件 Test conditions

- ・カバー付き with Cover
- ・周囲温度 Ambient temperature : 25 °C
- ・入力電圧 Input voltage : 100 , 230 VAC
- ・出力電圧 Output voltage : 定格 Rated
- ・出力電流 Output current : 100 %
- ・距離 Distance : 2.1 m
- ・スイープ・コンディション Sweep condition : 1.0 %ステップ, 1.0 秒保持
1.0 %step up, 1.0 s hold
- ・試験方向 Test angle : 上下, 左右, 前後
Top/Bottom , Both Sides , Front/Back
- ・電磁界周波数 Electromagnetic frequency : 80 MHz~2.7 GHz
- ・振幅変調 Amplitude modulated : 80 % , 1 kHz
- ・偏波 Wave angle : 水平, 垂直
Horizontal , Vertical

3.試験方法 Test method

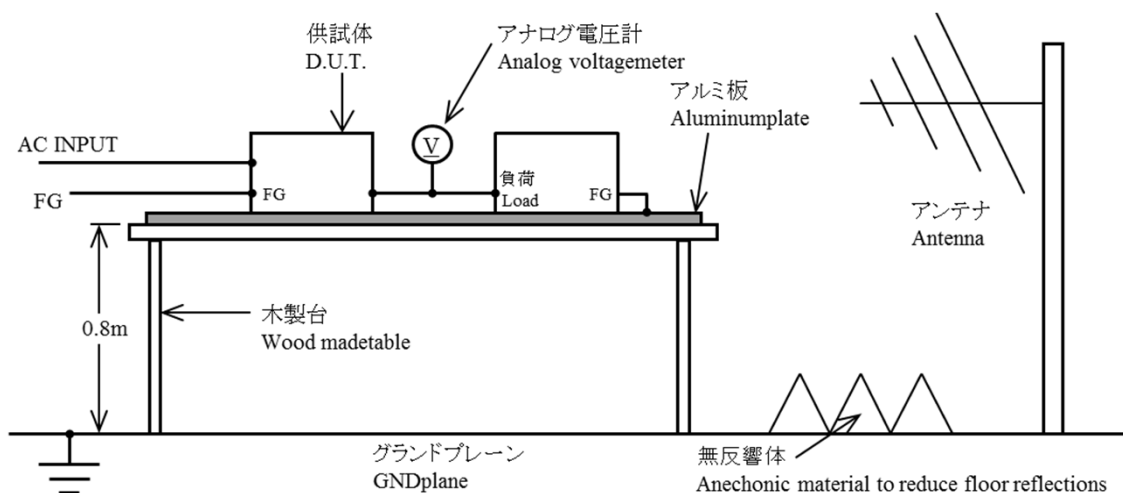

4.判定条件 Acceptable conditions

- ・試験中の出力電圧変動は、初期値(試験前)の±5%を超えないこと。
Output voltage regulation must not exceed ±5% of initial (before test) value during test.
- ・試験後の出力電圧は、初期値(試験前)から仕様範囲内の変動であること。
Output voltage after test shall be stable at the initial (before test) value (within specification range).
- ・試験中、発煙／発火及び出力低下が無いこと。
No discharge of fire or smoke, as well as no output failure during test.

5.試験結果 Test result

LEVEL	Radiation Field Strength(V/m)	Result
1	1	OK
2	3	OK
3	10	OK

MODEL | **LFS50A**電氣的ファーストランジェントバーストイミュニティ試験
Electrical Fast Transient / Burst Immunity Test(EN61000-4-4)

1.使用試験装置 Equipment used

- ・EFT/B発生器 EFT/B generator

2.試験条件 Test conditions

- ・カバー付き with Cover
- ・周囲温度 Ambient temperature : 25 °C
- ・入力電圧 Input voltage : 100 , 230 VAC
- ・出力電圧 Output voltage : 定格 Rated
- ・出力電流 Output current : 100 %
- ・パルス周波数 Pulse Frequency : 5kHz , 100kHz
- ・バースト期間 Burst Time : 15ms , 0.75ms
- ・バースト周期 Burst Cycle : 300ms
- ・極性 Polarity : + , -
- ・試験時間 Test time : 1 min.
- ・試験回数 Number of tests : 3 回 3 times

3.試験方法及び印加箇所 Test method and Device test points

全線(L , N , FG)に印加

Apply to All lines(L , N , FG).

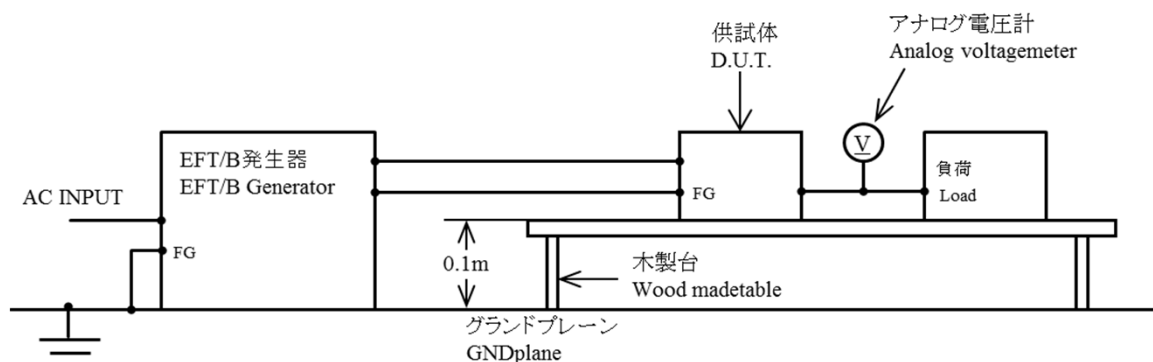

4.判定条件 Acceptable conditions

- ・試験中の出力電圧変動は、初期値(試験前)の±5%を超えないこと。
Output voltage regulation must not exceed ±5% of initial (before test) value during test.
- ・試験後の出力電圧は、初期値(試験前)から仕様範囲内の変動であること。
Output voltage after test shall be stable at the initial (before test) value (within specification range).
- ・試験中、発煙／発火及び出力低下が無いこと。
No discharge of fire or smoke, as well as no output failure during test.

5.試験結果 Test result

LEVEL	Test Voltage (kV)	Result
1	0.5	OK
2	1.0	OK
3	2.0	OK
4	4.0	OK

MODEL | **LFS50A**サージ免疫試験
Surge Immunity Test(EN61000-4-5)

1.使用試験装置 Equipment used

- ・サージ発生器 Surge generator

2.試験条件 Test conditions

- ・カバー付き with Cover
- ・周囲温度 Ambient temperature : 25 °C
- ・入力電圧 Input voltage : 100 , 230 VAC
- ・出力電圧 Output voltage : 定格 Rated
- ・出力電流 Output current : 100 %
- ・試験回数 Number of tests : 5 times
- ・極性 Polarity : + , -
- ・位相 Phase : 0 , 90 , 270 deg
- ・モード Mode : コモン , ノーマル (Common , Normal)

3.試験方法及び印加箇所 Test method and Device test points

コモンモード(L-FG , N-FG)及びノーマルモード(L-N)に印加
Apply to Common mode(L-FG , N-FG) and Normal mode(L-N).

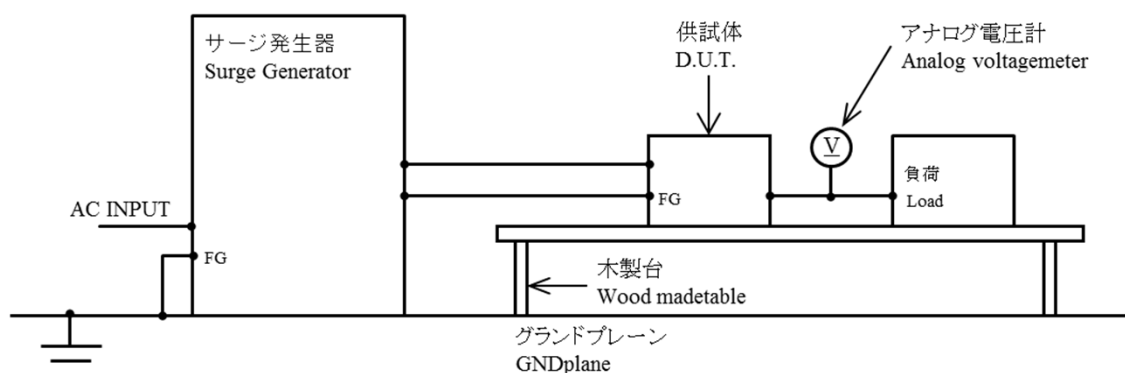

4.判定条件 Acceptable conditions

- ・試験中の出力電圧変動は、初期値(試験前)の±5%を超えないこと。
Output voltage regulation must not exceed ±5% of initial (before test) value during test.
- ・試験後の出力電圧は、初期値(試験前)から仕様範囲内の変動であること。
Output voltage after test shall be stable at the initial (before test) value (within specification range).
- ・試験中、発煙／発火及び出力低下が無いこと。
No discharge of fire or smoke, as well as no output failure during test.

5.試験結果 Test result

LEVEL	Test Voltage (kV)	Result		
		L-FG	N-FG	L-N
1	0.5	OK	OK	OK
2	1.0	OK	OK	OK
3	2.0	OK	OK	OK

MODEL LFS50A

伝導性無線周波数電磁界イミュニティ試験

Immunity to conducted disturbances, induced by radio-frequency fields (EN61000-4-6)

1. 使用試験装置 Equipment used

- ・RFパワーアンプ RF POWER AMPLIFIER
- ・シグナルジェネレータ SIGNAL GENERATOR
- ・結合/減結合ネットワーク(CDN) COUPLING DE-COUPLING NETWORK(CDN)

2. 試験条件 Test conditions

- ・カバー付き with Cover
- ・周囲温度 Ambient temperature : 25 °C
- ・入力電圧 Input voltage : 100 , 230 VAC
- ・出力電圧 Output voltage : 定格 Rated
- ・出力電流 Output current : 100 %
- ・スイープ・コンディション Sweep condition : 1.0 %ステップ, 1.0 秒保持
1.0 %step up, 1.0 s hold
- ・電磁界周波数 Electromagnetic frequency : 150 kHz~80 MHz

3. 試験方法 Test method

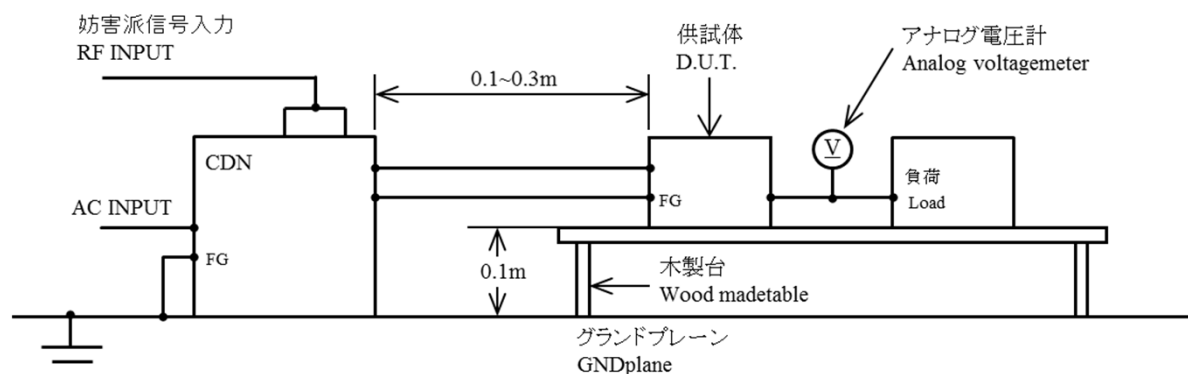

4. 判定条件 Acceptable conditions

- ・試験中の出力電圧変動は、初期値(試験前)の±5%を超えないこと。
Output voltage regulation must not exceed ±5% of initial (before test) value during test.
- ・試験後の出力電圧は、初期値(試験前)から仕様範囲内の変動であること。
Output voltage after test shall be stable at the initial (before test) value (within specification range).
- ・試験中、発煙/発火及び出力低下が無いこと。
No discharge of fire or smoke, as well as no output failure during test.

5. 試験結果 Test result

LEVEL	Voltage Level (V)	Result
1	1	OK
2	3	OK
3	10	OK

MODEL LFS50A

電力周波数磁界イミュニティ試験

Power Supply-Frequency Magnetic Field Immunity Test (EN61000-4-8)

1. 使用試験装置 Equipment used

- 電源周波数磁界試験装置 Power supply-frequency magnetic field testing machine

2. 試験条件 Test conditions

- カバー付き with Cover
 - 周囲温度 Ambient temperature : 25 °C
 - 入力電圧 Input voltage : 100 , 230 VAC
 - 出力電圧 Output voltage : 定格 Rated
 - 出力電流 Output current : 100 %
 - 印加方向 Direction : X , Y , Z
 - 印加磁界周波数 : 50 , 60 Hz
- Input magnetic frequency
- 試験時間 Test time : 1 min(各方向/Each direction)

3. 試験方法 Test method

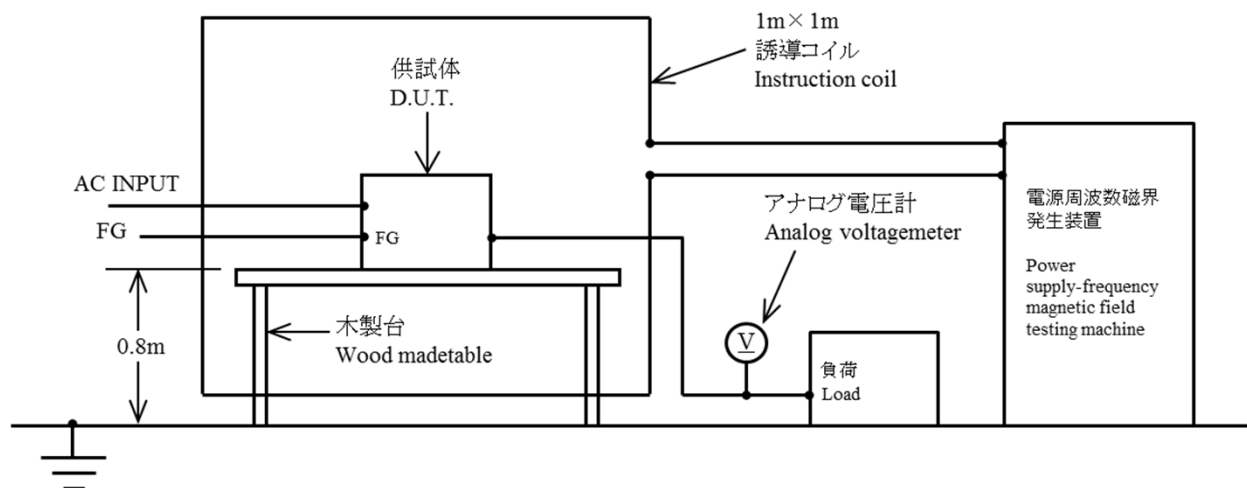

4. 判定条件 Acceptable conditions

- 試験中の出力電圧変動は、初期値(試験前)の±5%を超えないこと。
Output voltage regulation must not exceed ±5% of initial (before test) value during test.
- 試験後の出力電圧は、初期値(試験前)から仕様範囲内の変動であること。
Output voltage after test shall be stable at the initial (before test) value (within specification range).
- 試験中、発煙/発火及び出力低下が無いこと。
No discharge of fire or smoke, as well as no output failure during test.

5. 試験結果 Test result

LEVEL	Magnetic Field Strength (A/m)	Result
1	1	OK
2	3	OK
3	10	OK
4	30	OK

MODEL LFS50A-12

振動試験
Vibration Test

1.使用試験装置 Equipment used

- ・振動試験装置 Vibration testing machine

2.試験条件 Test conditions

- ・非動作 No operating.
- ・周囲温度 Ambient temperature : 25°C
- ・周波数範囲 Sweep frequency : 10-55Hz
- ・掃印時間 Sweep time : 1分間 1min.
- ・振動方向 Direction : X, Y, Z
- ・試験時間 Test time : 各方向60分間 60 min. each
- ・加速度 Acceleration : 19.6m/s² 一定

3.試験方法 Test method

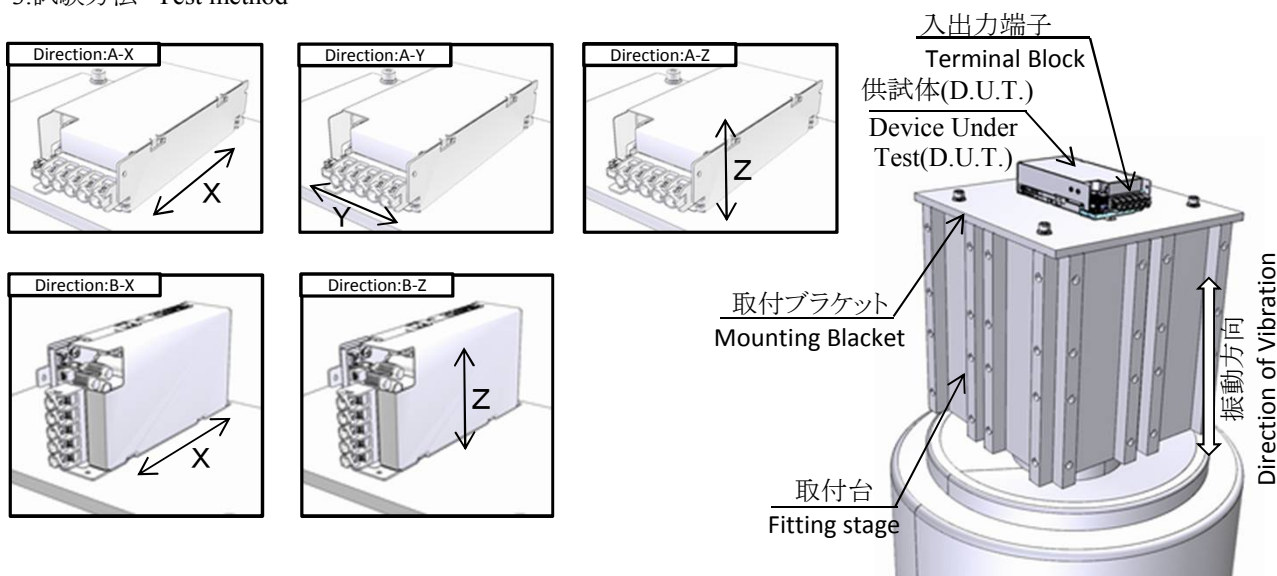

4.試験結果 Test result

- ・確認条件 Check condition : 周囲温度 Ambient temperature 22 °C
- : 入力電圧 Input voltage 100 VAC
- : 出力電流 Output current 100 %

確認項目 Check item	出力電圧 Output voltage	出力リップルノイズ Output ripple noise	外観状態 State of appearance
試験前 Before test	12.02 V	5.3 mVp-p	異常無し OK
試験後 After test	12.02 V	4.8 mVp-p	異常無し OK

MODEL | **LFS50A-12**

衝撃試験
Impact Test

1. 使用試験装置 Equipment used

- ・ 振動試験装置 Vibration testing machine

2. 試験条件 Test conditions

- ・ カバー付き with Cover
- ・ 非動作 No operating.
- ・ 周囲温度 Ambient temperature : 25 °C
- ・ パルス波形 Pulse waveform : 正弦半波 Half-sine waveform
- ・ ピーク加速度 Peak acceleration : 300 m/s²
- ・ 衝撃方向 Direction : X, Y, Z
- ・ 試験時間 Test time : 11 ms X, Y, Z方向 各1回
11 ms, once each X, Y and Z axis 1times

3. 試験方法 Test method

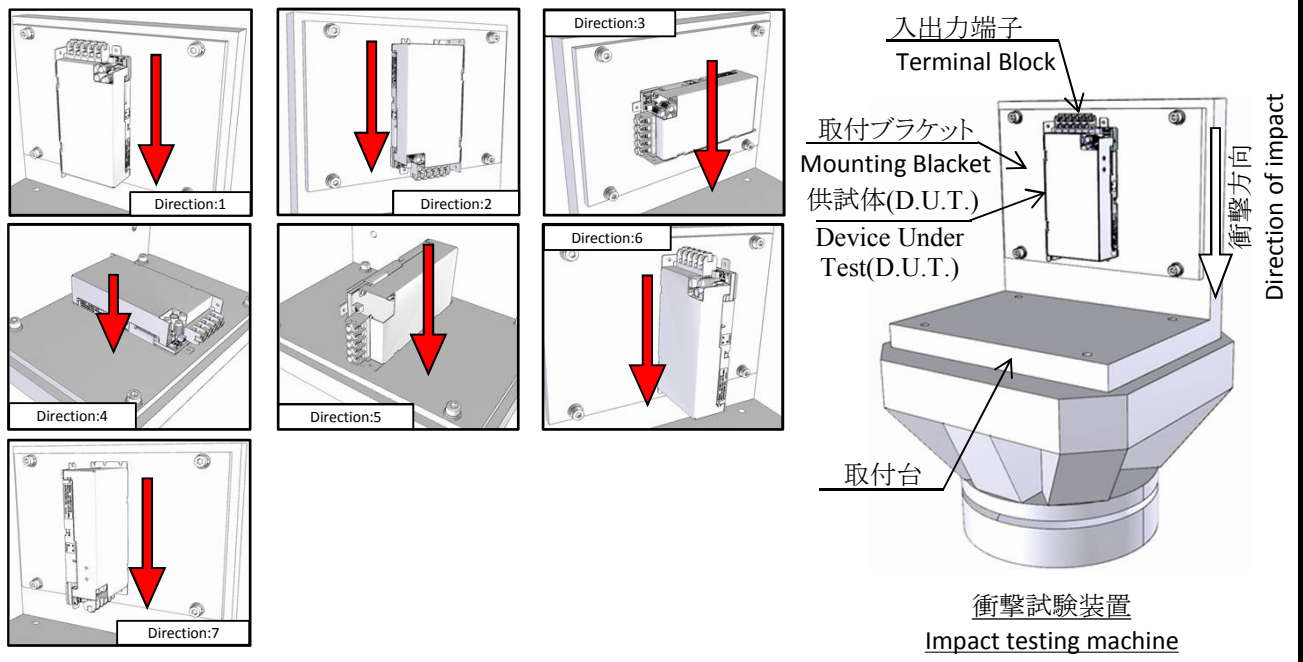

4. 試験結果 Test result

- ・ 確認条件 Check condition : 周囲温度 Ambient temperature 22 °C
- : 入力電圧 Input voltage 100 VAC
- : 出力電流 Output current 100 %

確認項目 Check item	出力電圧 Output voltage	出力リップルノイズ Output ripple noise	外観状態 State of appearance
試験前 Before test	12.02 V	5.2 mVp-p	異常無し OK
試験後 After test	12.02 V	4.5 mVp-p	異常無し OK

Calculated values of MTBF

JEITA RCR-9102B

1. 算出方法 Part count reliability projection

MIL-HDBK-217F NOTICE 2の部品点数信頼度予測法により算出されています。

Calculated based on part count reliability projection of MIL-HDBK-217F NOTICE 2.

<算出式>

$$\lambda_{equip} = \sum_{i=1}^{i=n} N_i (\lambda_g \pi_q)_i \quad \text{式を簡単にする為に品質ファクタ } \pi_q = 1 \text{ とする。}$$

$$MTBF = \frac{1}{\lambda_{equip}} \times 10^6 = \frac{1}{\sum_{i=1}^{i=n} N_i (\lambda_g)_i} \times 10^6 \quad \text{[時間] [hour]}$$

λ_{equip} : 全機器故障率 (故障率/10⁶時間)
Total Equipment Failure Rate.(Failure/10⁶ hour)

λ_g : i番目の同属部品に対する故障率 (故障率/10⁶時間)
Generic Failure Rate for The ith Generic Part.

π_q : i番目の同属部品に対する品質ファクタ
Generic Quality Factor for The ith Generic Part.

N_i : i番目の同属部品個数
Quantity of ith Generic Part.

n : 異なった同属部品のカテゴリの数
Number of Different Generic Part Categories.

2. MTBF 値

G_F : 地上・固定 (Ground, Fixed)

$$MTBF = 1 \times 10^6 / 4.442 = \frac{225,106}{\text{hour}} \quad \frac{25.7}{\text{year}}$$